



IT-Services. FAIR, KOMPETENT und SICHER.



Topologieoptimierung im Creo-Umfeld mit ProTopCI

Urs Simmler, CAD Simulations Experte, GIA Informatik AG, Oftringen (Schweiz)



- Vorstellung Präsentator
- Vorstellung GIA Informatik AG
- Warum Topologieoptimierung?
- ProTOpCI von CAESS



- ProTOpCI: Live Demo
- Fragen

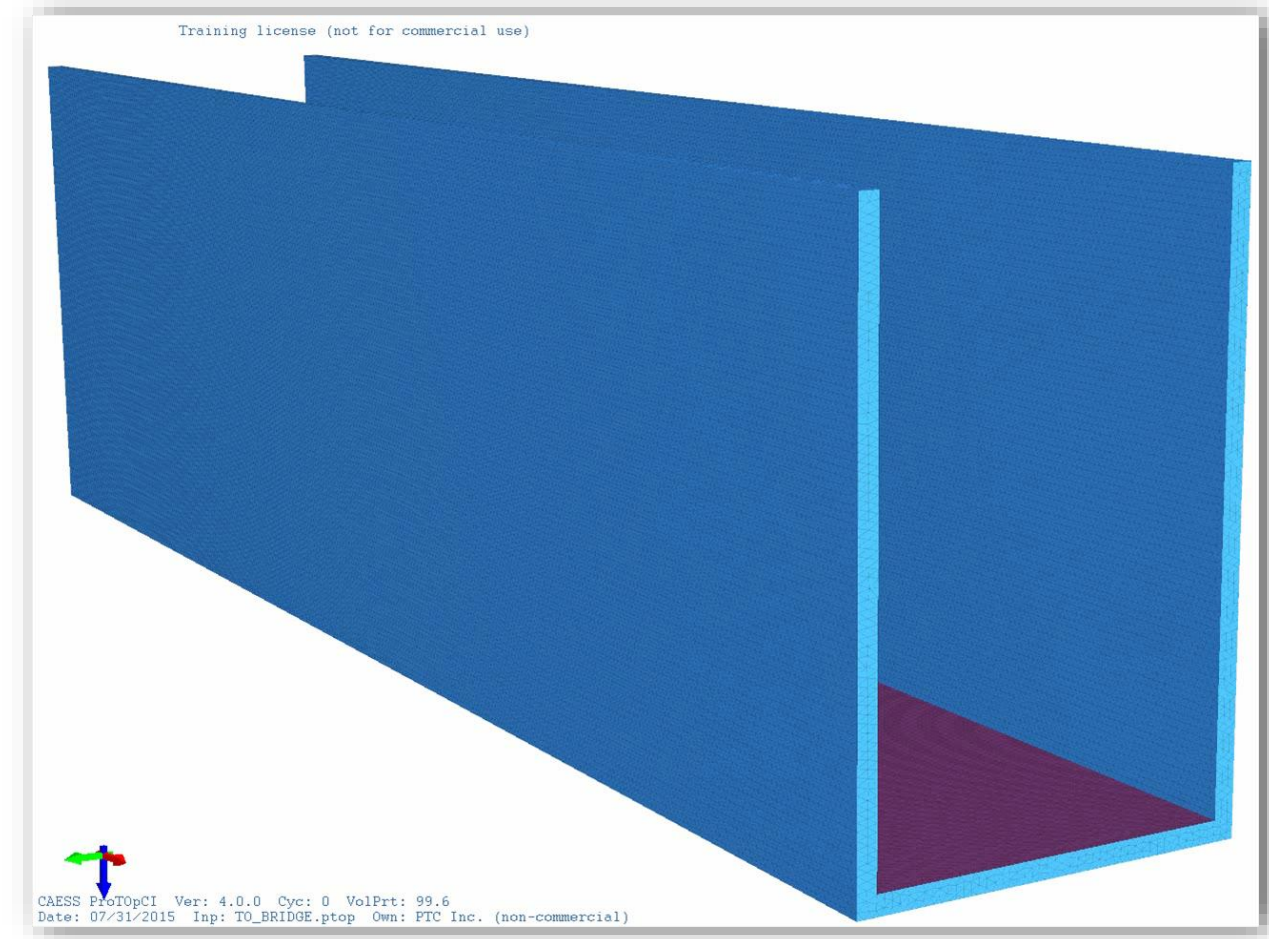

- Fokus auf Creo Simulations-Lösungen
- Presales / Training / Consulting:
 - Creo Simulate (Pro Mechanica)
 - Creo Mechanism (MDX, MDO)
 - Creo Animation (DAO)
 - Creo Manikin
 - Creo Behavioral Modelling (BMX)
 - Creo Spark Analysis (SAX)
 - Creo Mold Analysis (MAX)
 - Mathcad
 - ProTOpCI (Topology Optimization, CAESS, PTC Partner Advantage Silver)
 - FLoEFD (CFD-Simulation, Mentor)
- 28 Jahre Simulations-Erfahrung
- davon 20 Jahre bei PTC als Application Engineer



Urs Simmler

CAD Simulations Experte

GIA Informatik AG (Schweiz)

mail: urs.simmler@gia.ch
mobile: **+41 76 574 90 16**



Oftringen

MÜLLER MARTINI

Seit 1988 mitten in der Schweiz

145 erfahrene Mitarbeitende

Unternehmen der Müller Martini Gruppe

- SAP Lösungen
- IT-Services
- CAD / CAM / CAE / PLM

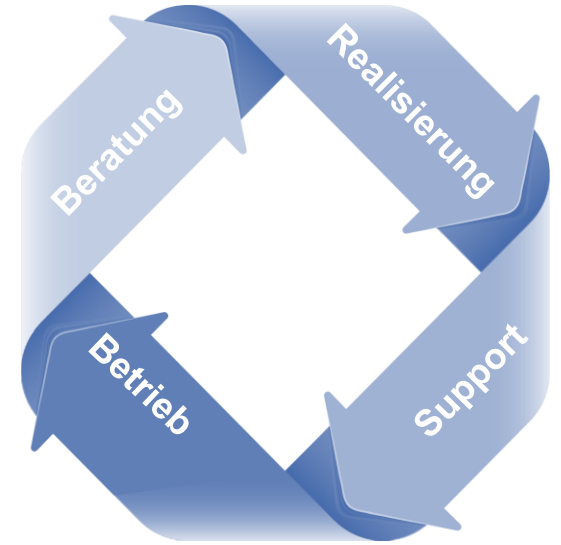

Partner



Partner

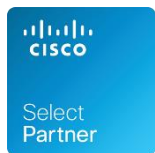

- Topologieoptimierung in Wikipedia:
«Computerbasiertes Berechnungsverfahren, durch welches eine günstige Grundgestalt (Topologie) für Bauteile unter mechanischer Belastung ermittelt werden kann.»
- 3D-Druck-Verfahren revolutioniert Gestaltung der Komponenten
 - Form unabhängig vom Fertigungsverfahren
 - optimale Gitterstrukturen innerhalb der Komponenten wichtig
- Creo Umfeld:
 - ProTopCI (CAESS, PTC Partner Advantage)

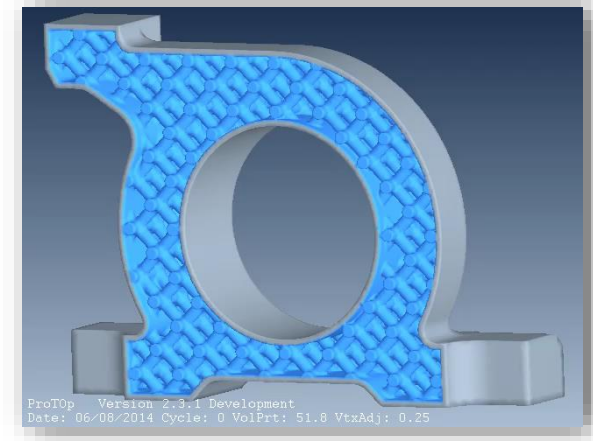
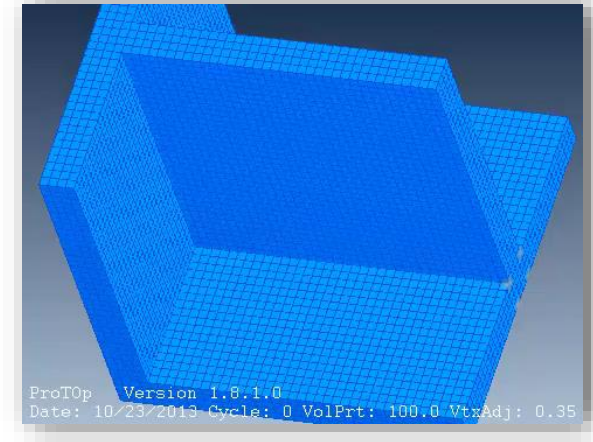

Warum Topologieoptimierung?

- Innovative Design-Ideen

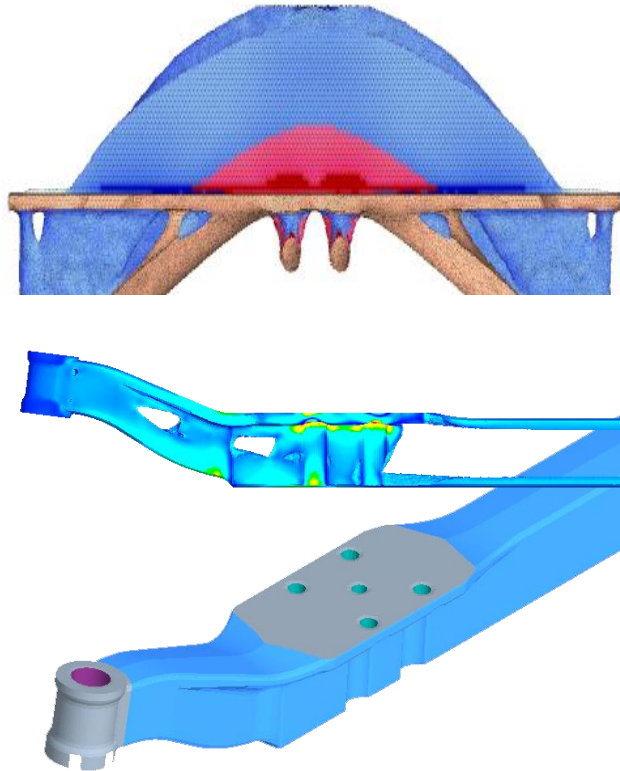

- Effizientes Re-Design

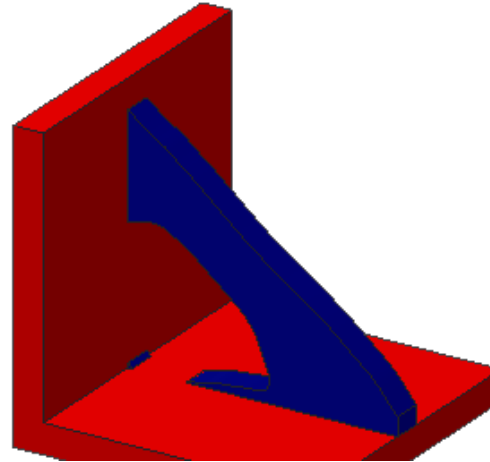
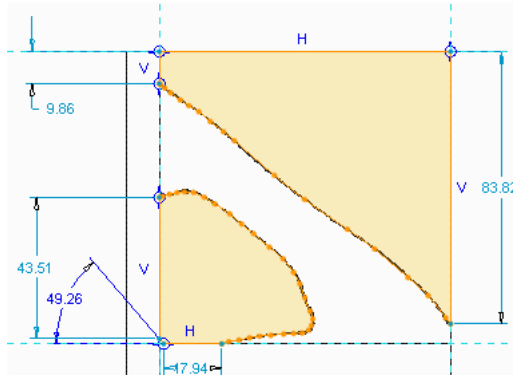

- Fertige Modelle für 3D-Druck

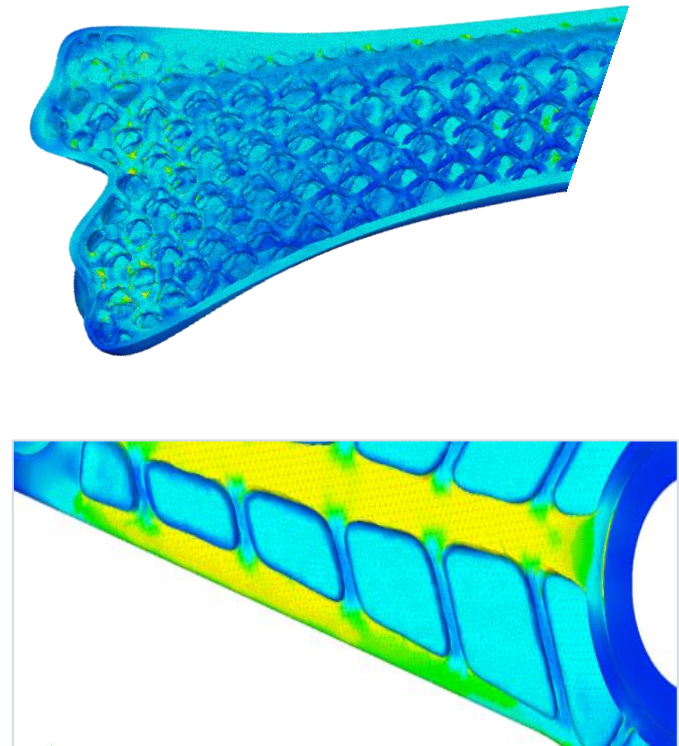

Warum Topologieoptimierung?

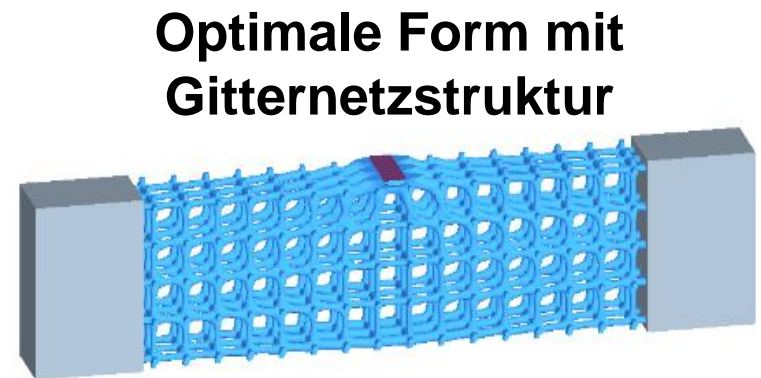
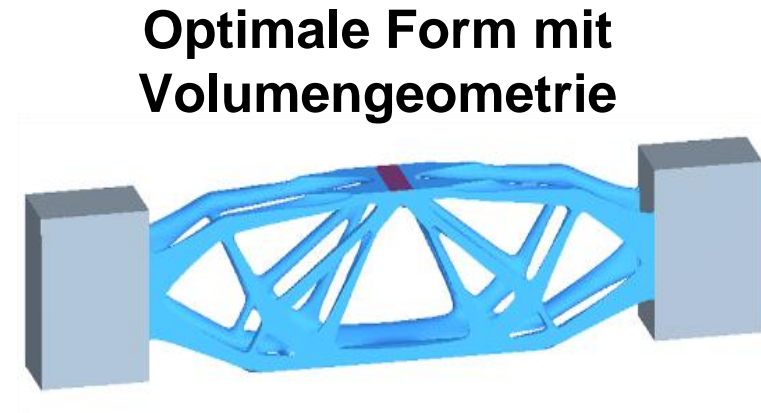
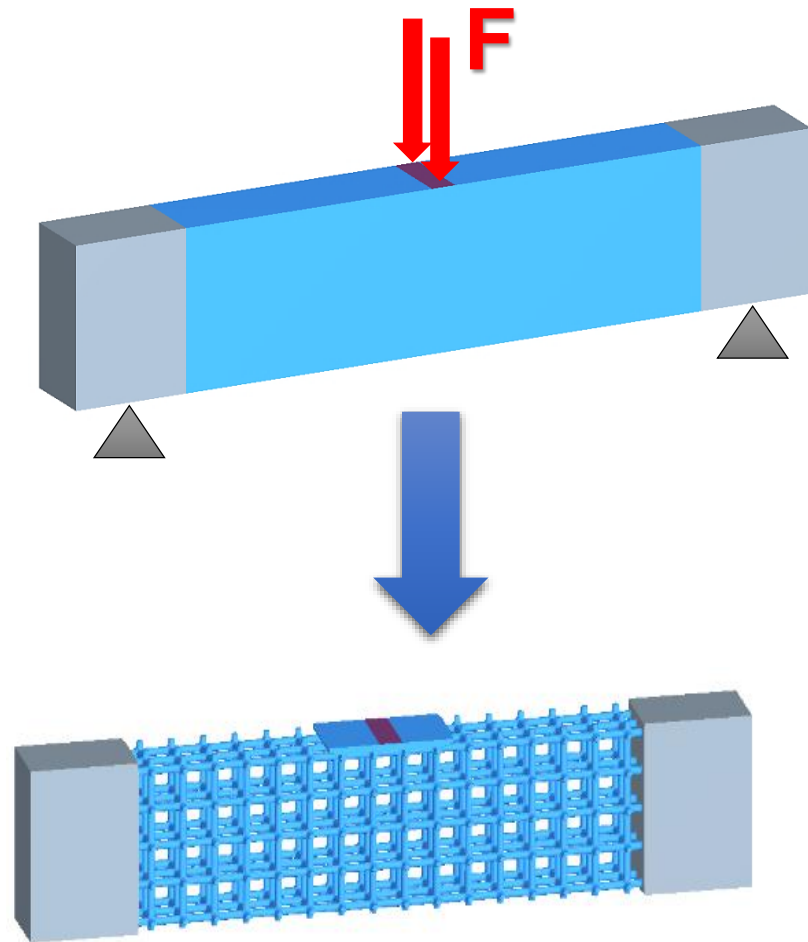

- CAESS, PTC Partner Advantage, Silver
- Maribor, Slowenien, 20 MA
- <http://www.caess.eu/index.html>

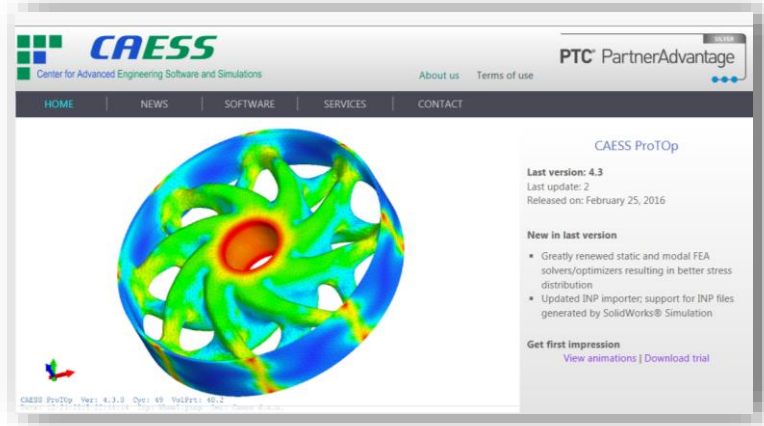

- ProTopCI: PTC Creo Simulate (linked)
- ProTop: PTC Creo Simulate, Simulia Abaqus, SolidWorks Simulation (standalone)

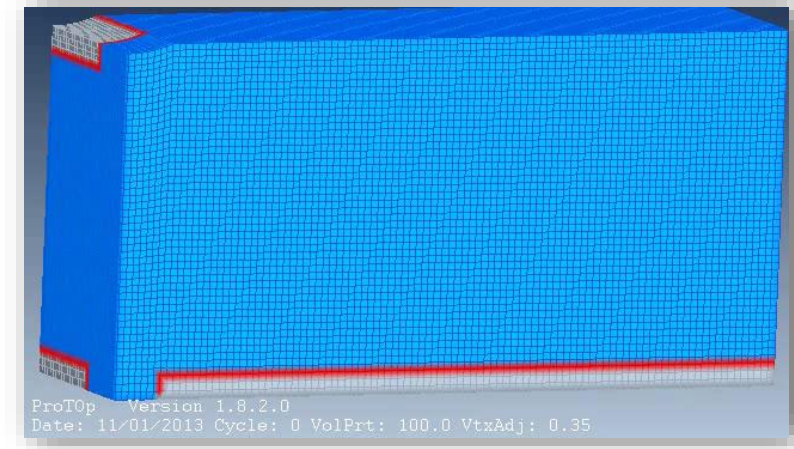
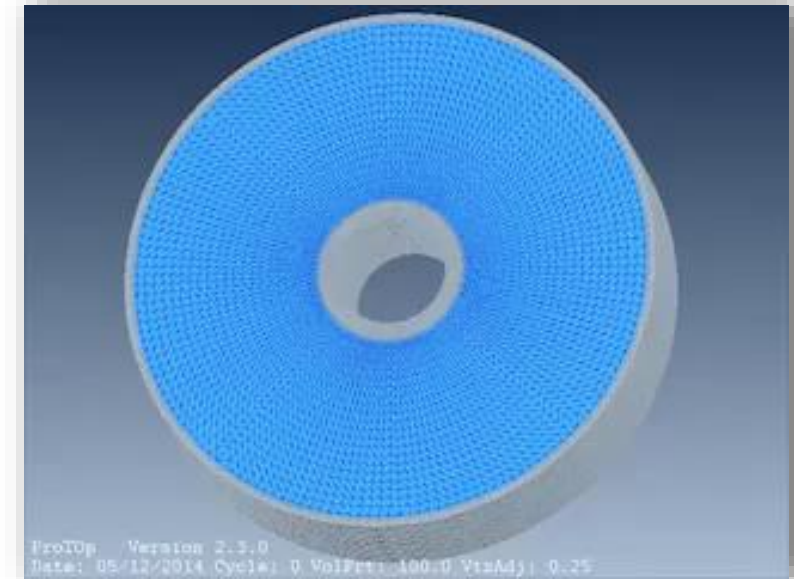

- Vorteile:

- Kostengünstige, benutzerfreundliche Software
- Leistungsstarke Strukturen mit weniger Material
- Linked / standalone Software mit eigenem FEA-Solver ; extrem schnell, parallelisiert, keine Scripts
- Interaktive Optimierung und Zielanpassungen auf Wunsch
- Optimierung mit Volumen-, Schalen-Geometrie, sowie Gitterstrukturen
- Oberflächenglättung an optimierten Komponenten ermöglicht direkte Verwendung für 3D-Druck und Herstellung

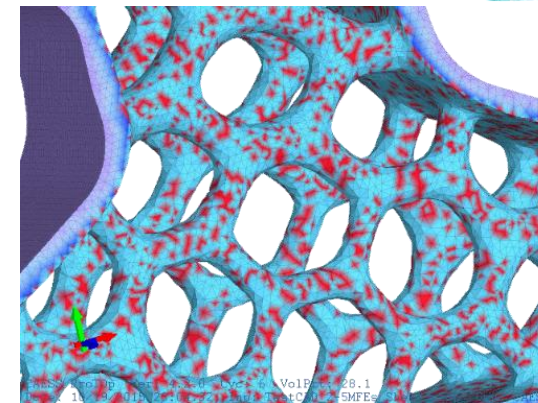
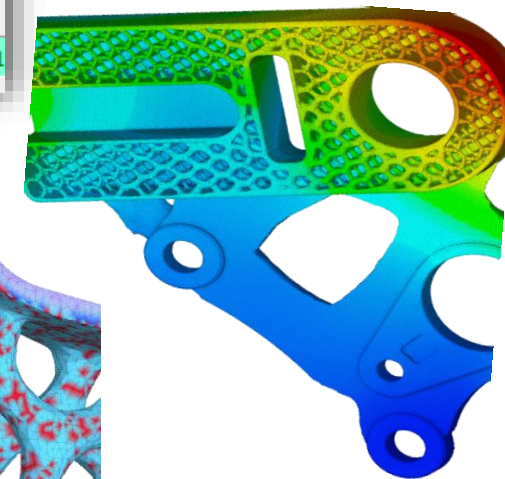
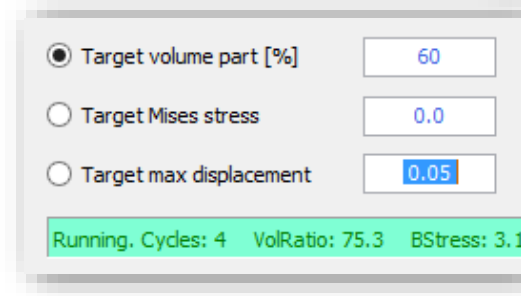
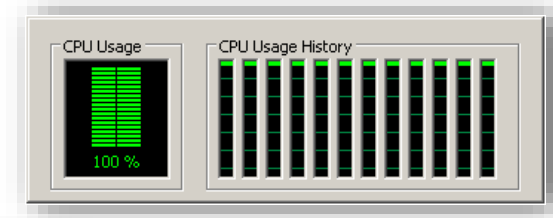

• Ablauf Topologieoptimierung:

1. Design Space
2. Finite Element Model (Creo Simulate)
3. Optimization Model
4. Topology Optimization
5. Reconstruction to Parametric Geometry
6. Validation FEAs (Creo Simulate)
7. Shape Correction
8. Optimized Geometry

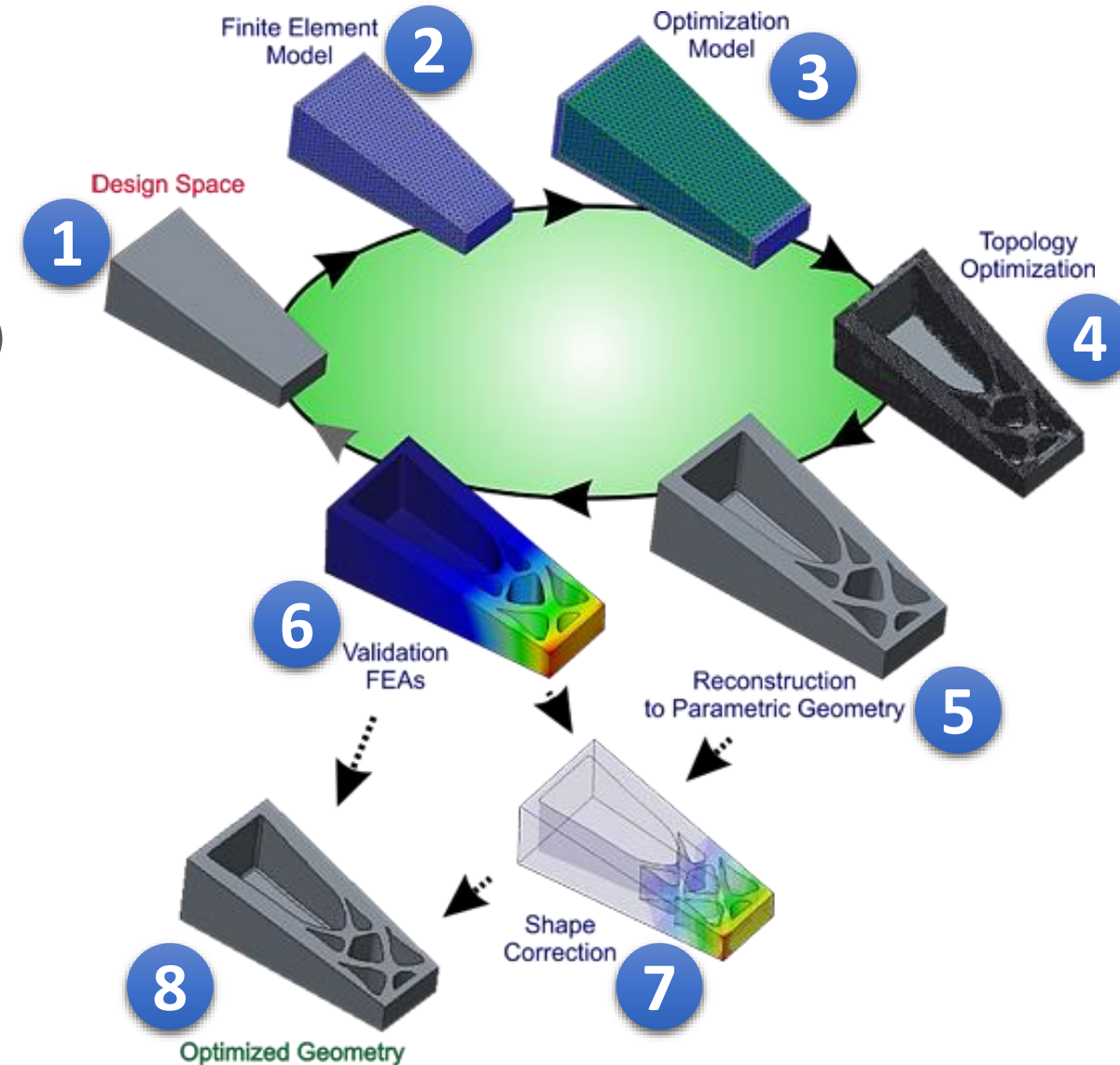

• Erzeugen des Simulationsmodells in Creo Simulate (FEM-Mode) mit

- Volumenbereichen
- Materialien
- Randbedingungen
- Lasten
- Netz-Steuerungen
- Last-Sätzen
- Randbeding.-Sätzen
- Analysen

• Run ProTop

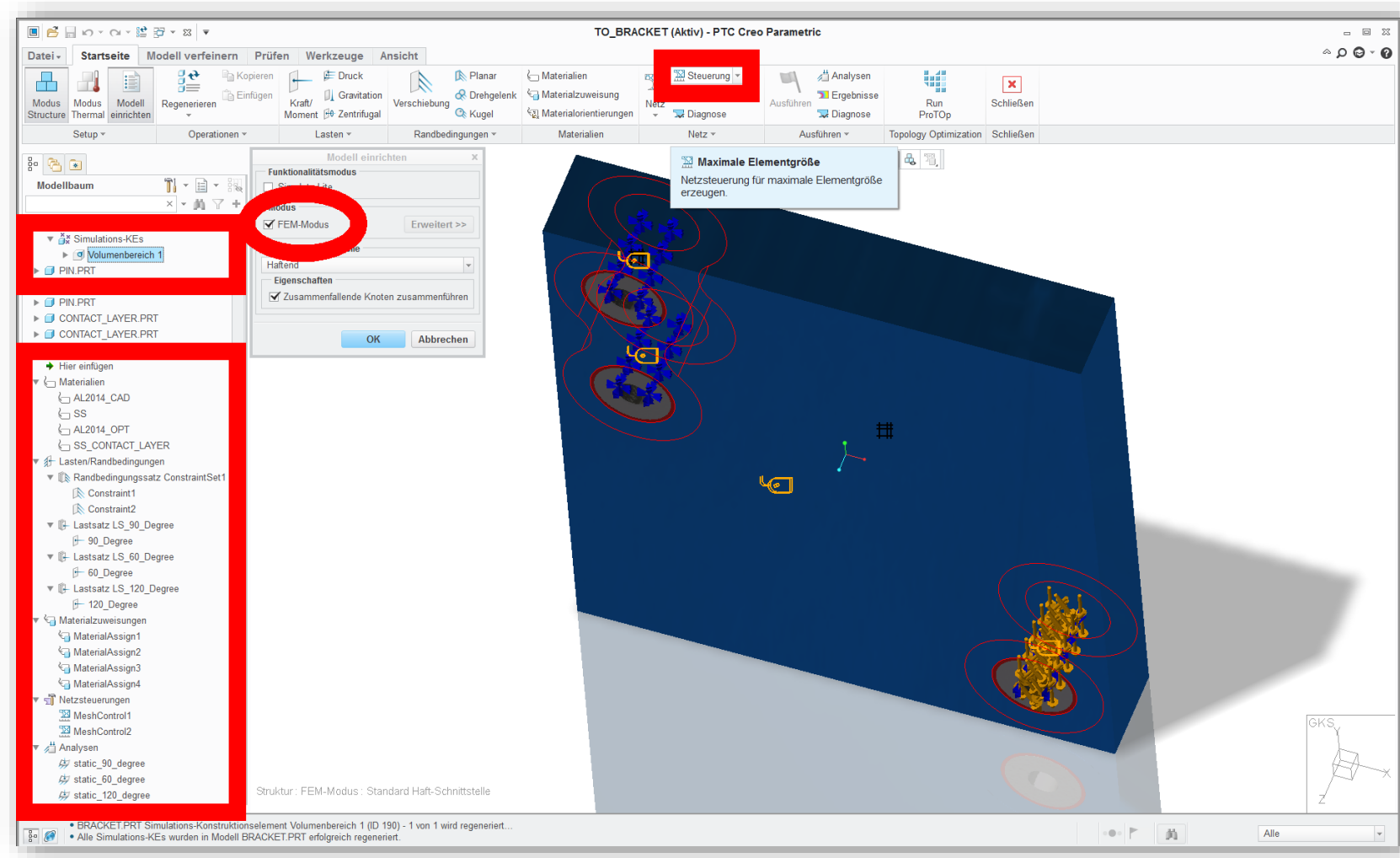
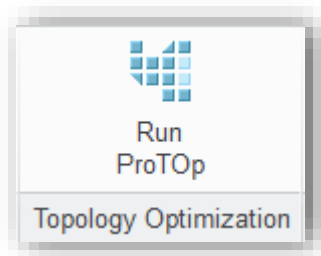

- ProTop startet mit FE-Model

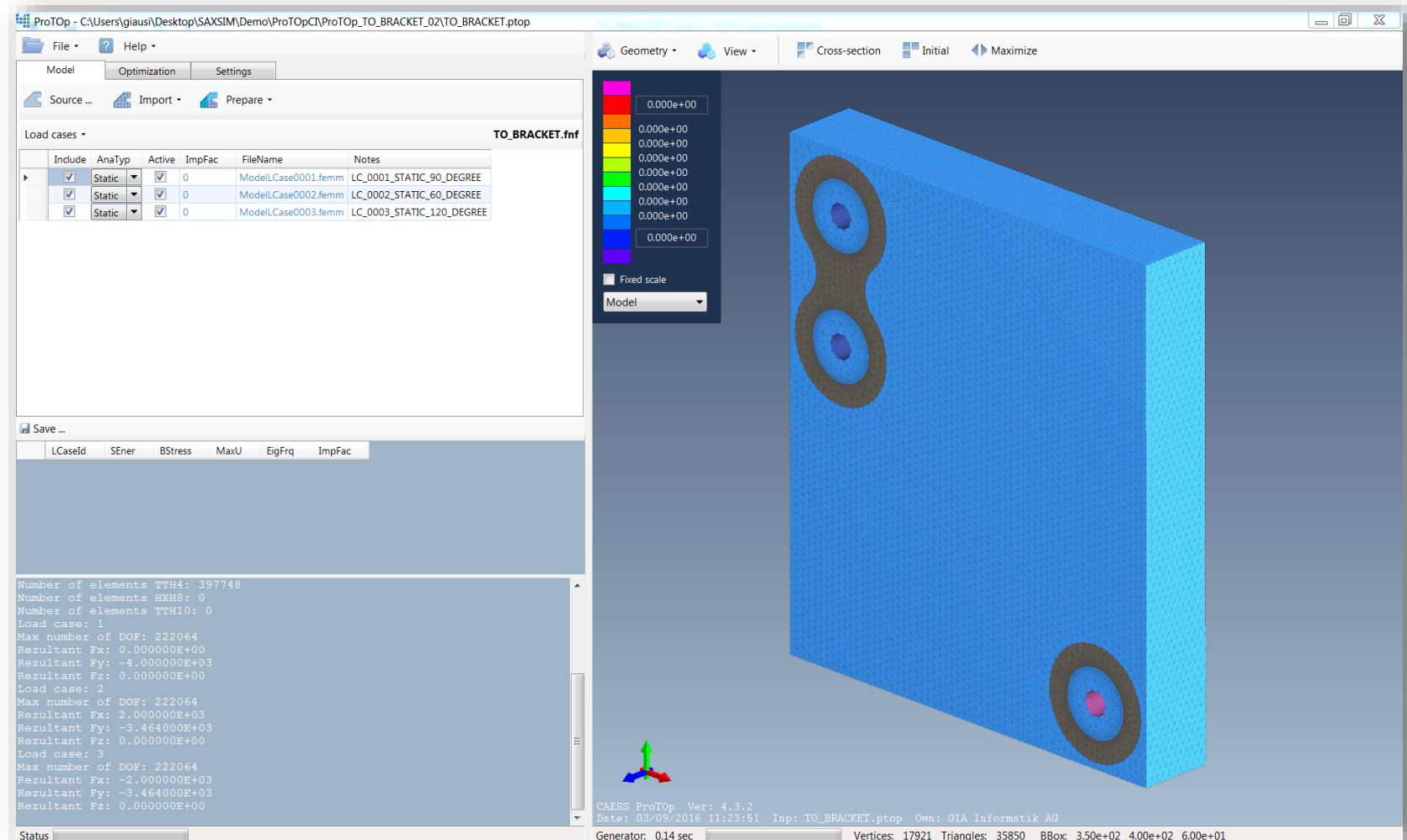
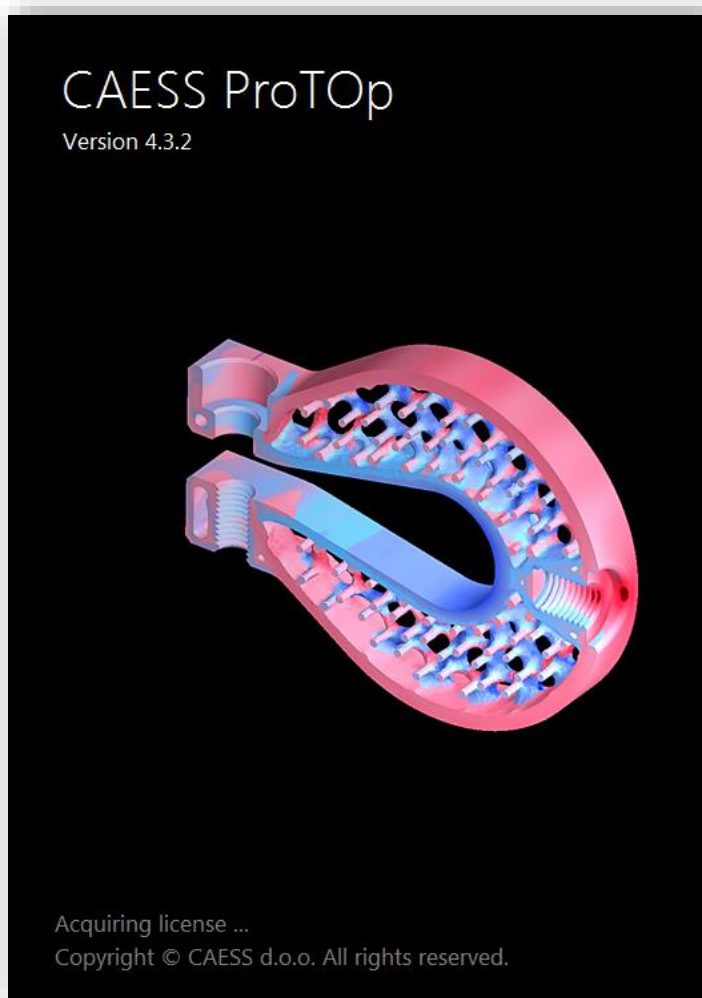

• Material Regions

- Light blue – Free region (modified by the optimizer)
- Light gray – Fixed region (not modified by the optimizer)
- Gray – FixedCAD region; excluded from FEA (e.g., if needed for 3D print, no BCs and Loads on FixedCAD regions)
- Black - FixedContact

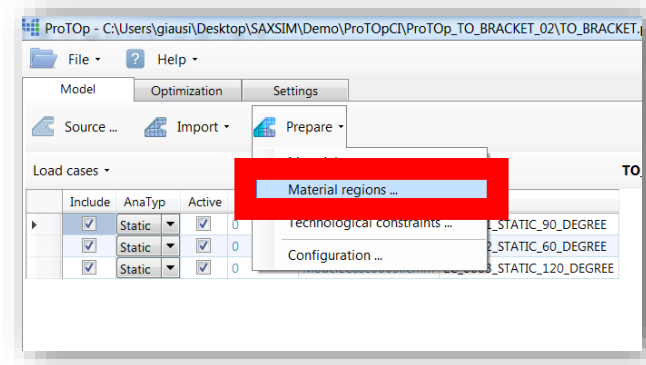

Id	Name	Type	Notes
1	STEEL_FIXC	FixedContact	
2	TIALLY	Free	
3	STEEL_FIX	Fixed	
4	TIALLY_FIX	Fixed	
5	TIALLY1_CAD	FixedCAD	
6	TIALLY_CAD	FixedCAD	

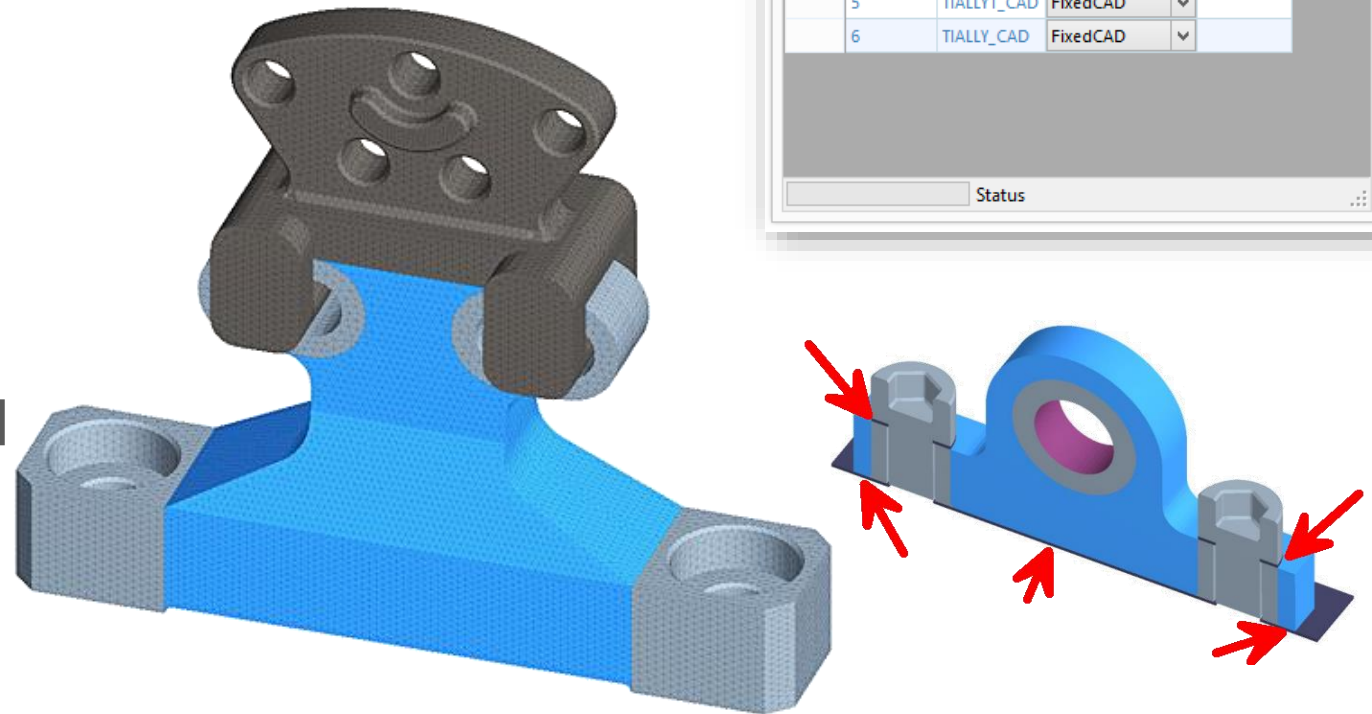

- Technological (Design) constraints

- Uni-directional opening with optional draft angle
- Bi-directional opening
- Plane symmetry
- Axisymmetry
- Constraints like uni-directional opening are important for technological (production) reasons

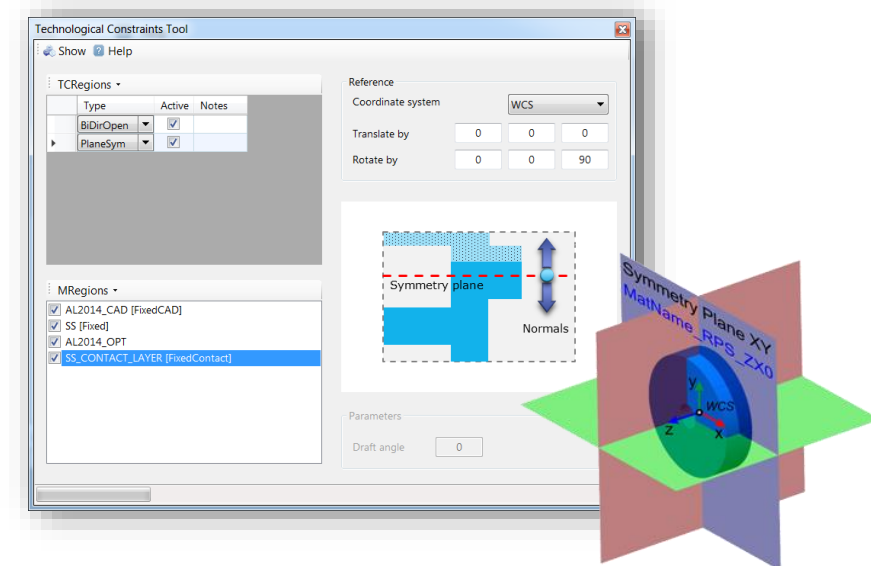
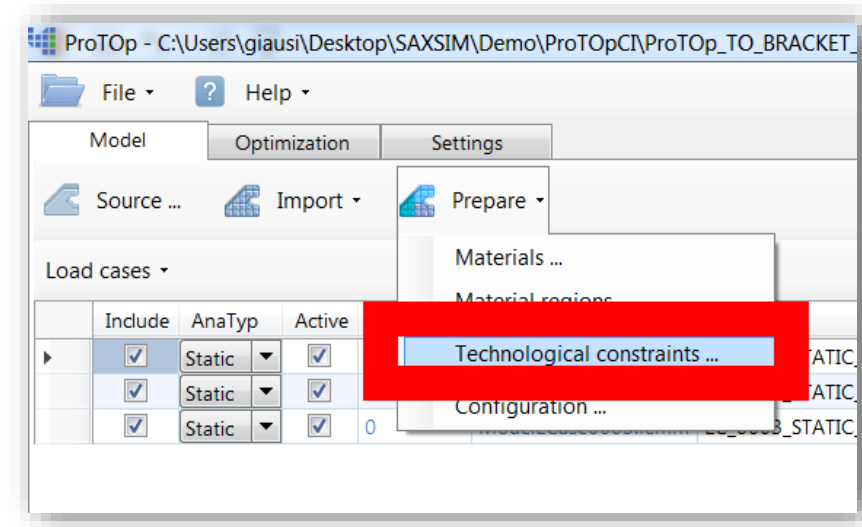
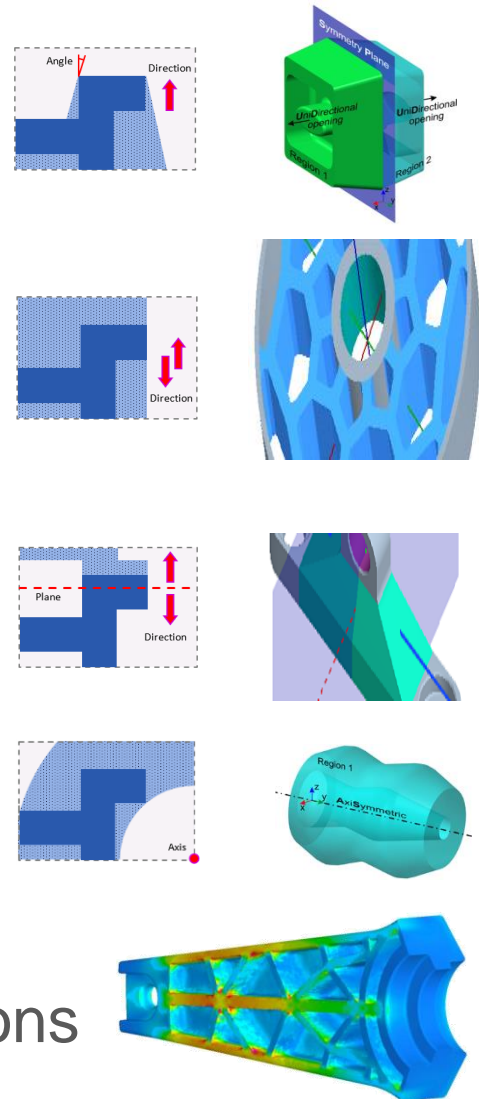

• Model Configuration

- Lattice
- Shell
- Mixed lattice / shell / solid

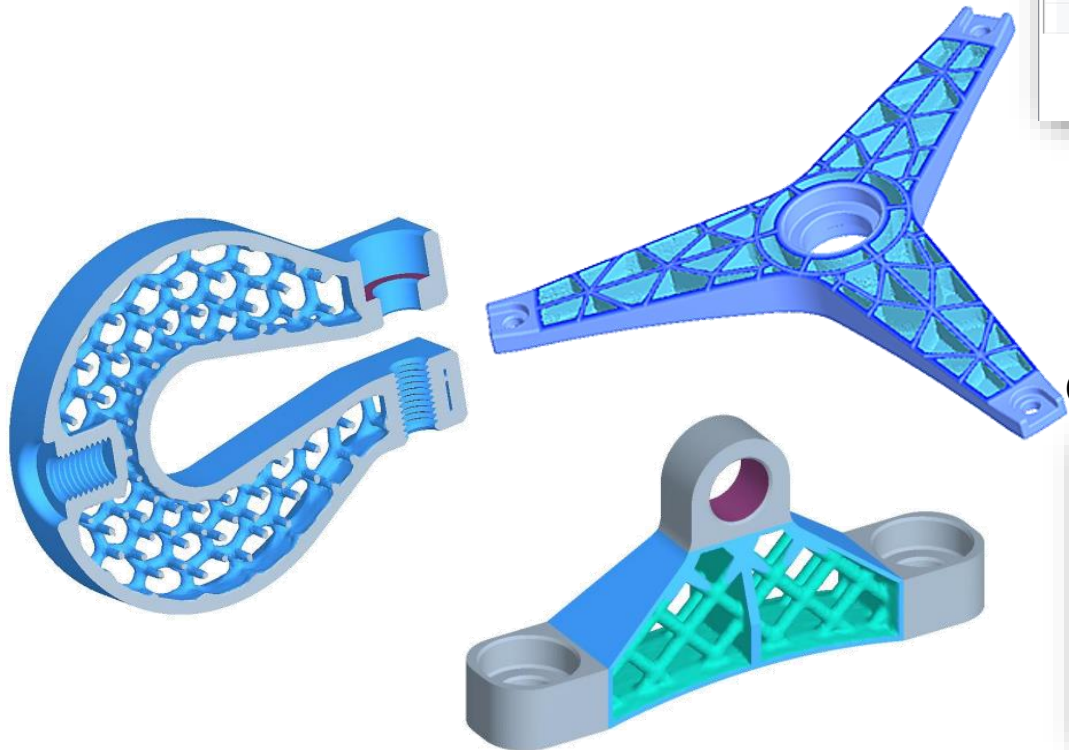
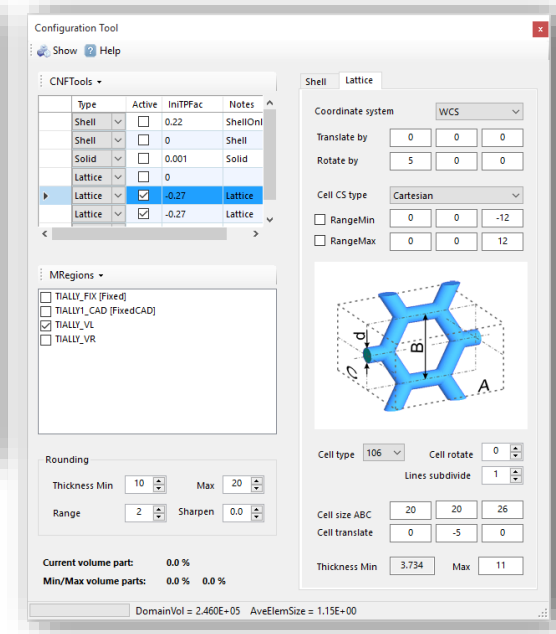
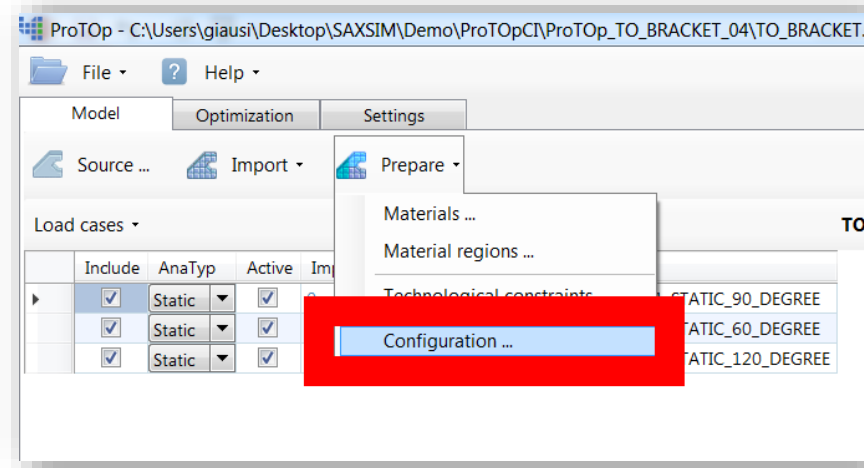

Cylindrical CS

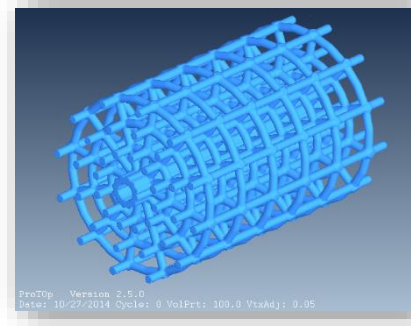

Spherical CS

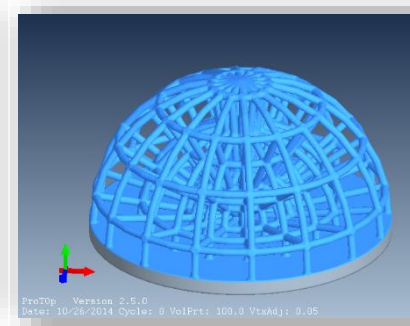

Cartesian CS

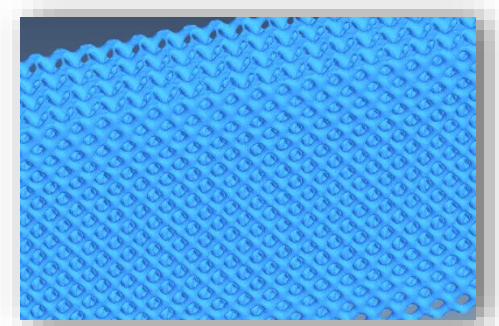

- Model Configuration
 - Lattice-Types

– 1D

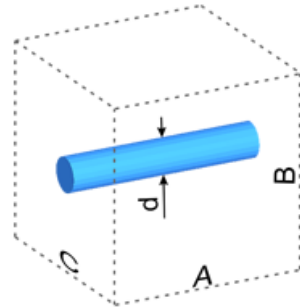

– 2D

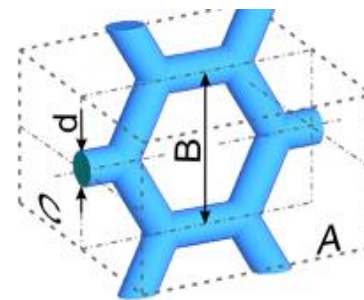
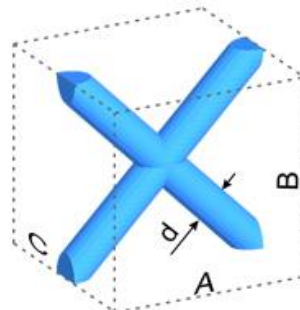
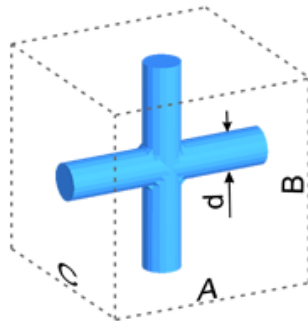

– 3D

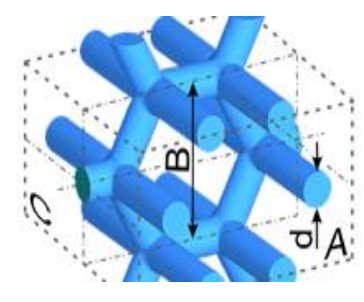
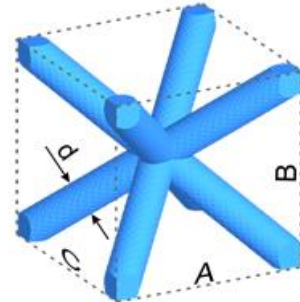
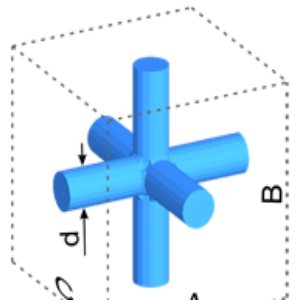

Wall from lattice

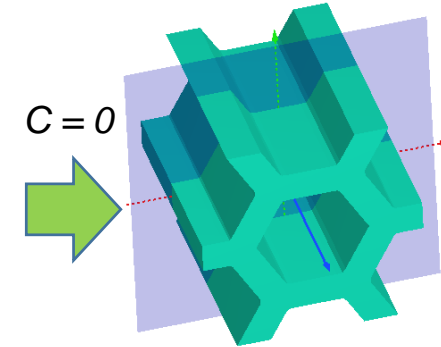

• Special Features

- Custom semi-contact elements enable for computationally efficient and numerically robust modeling of the most common contact situations such as
 - Pin joints
 - Pin loading
 - Bolts / rivets fastening

- Prestrained Region
 - Bolts / rivets fastening

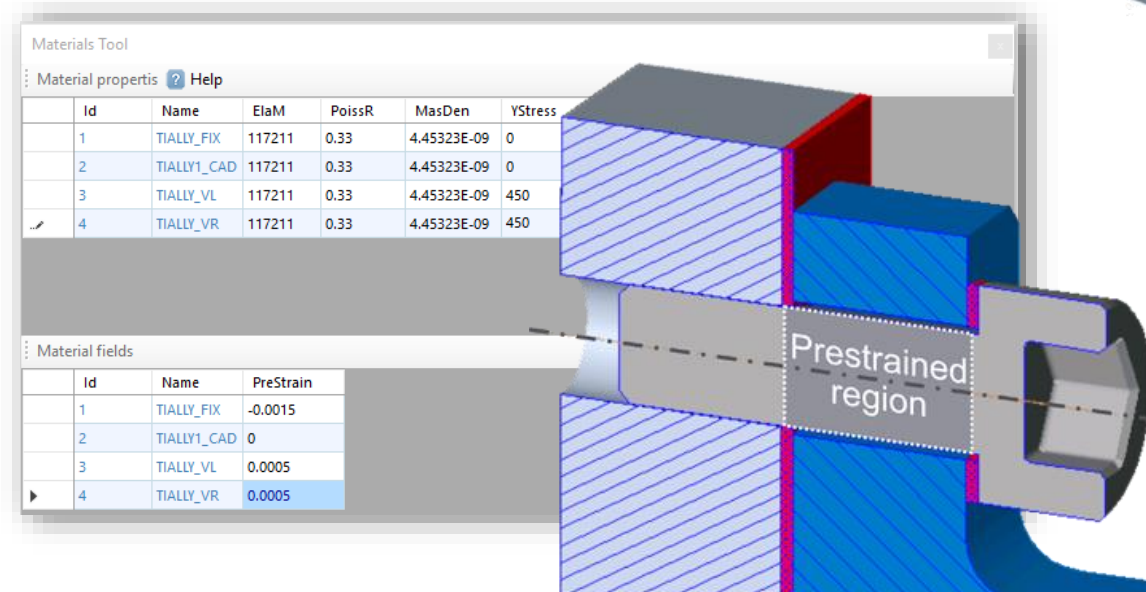
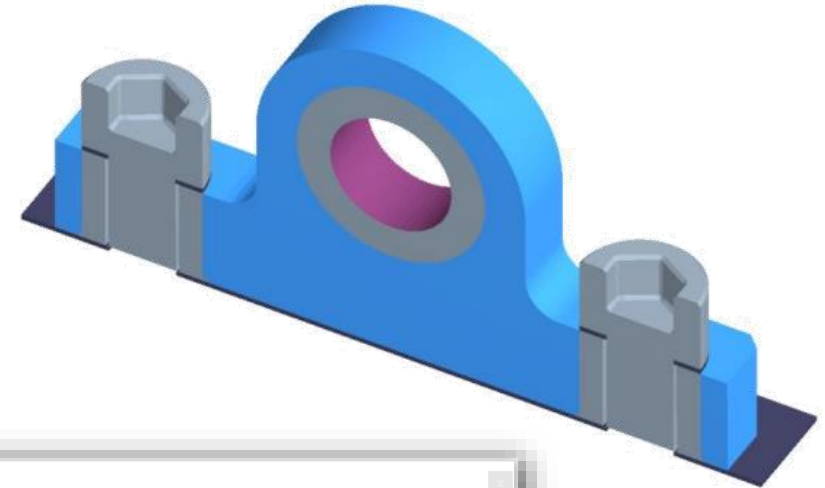

• Run Optimization

- ProTOp is designed to be fully interactive
- During an active optimization session, it is possible to visually monitor the progress and:
 - Change targeting options and values
 - Activate and deactivate individual load cases on the basis of their impact factors
 - Activate or deactivate semi-plastic behavior of materials and adjust the related parameters
 - Adjust tuning parameters
 - Switch between single and double-precision FEA solver
 - Pause and continue or restart optimization sessions

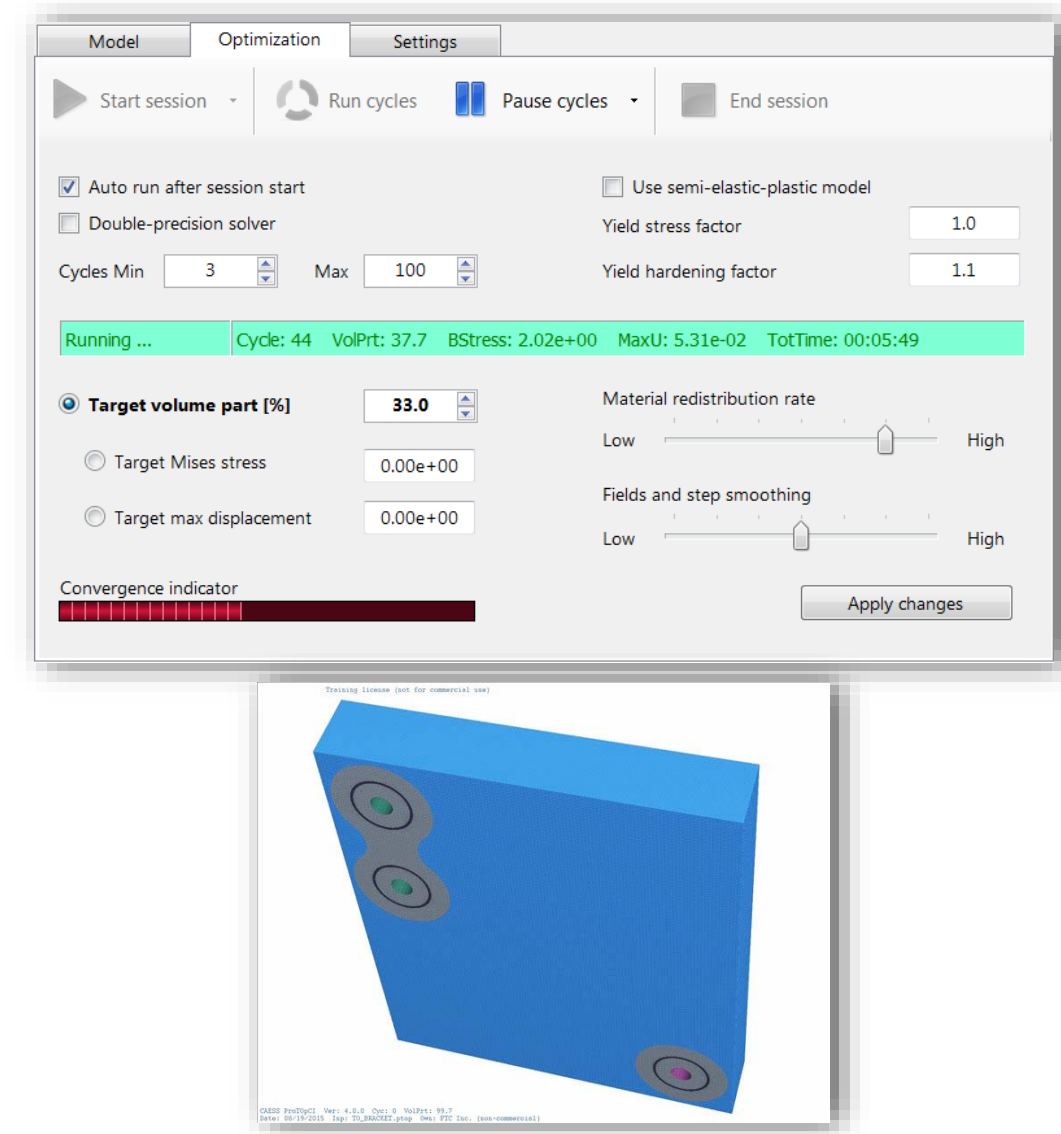

• Surface Tools

- Surface mesh errors check
- Mesh simplification
- Peaks and pits removal
- Smoothing

Surface after optimization

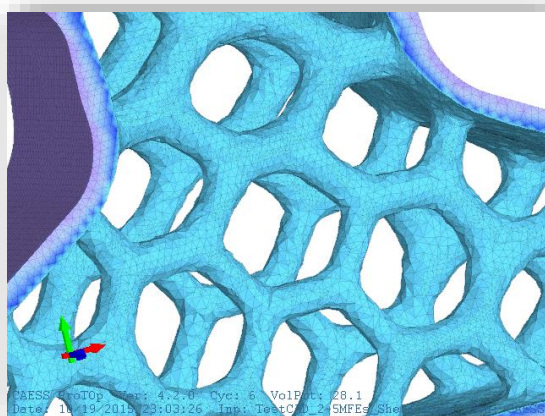

Smoothing

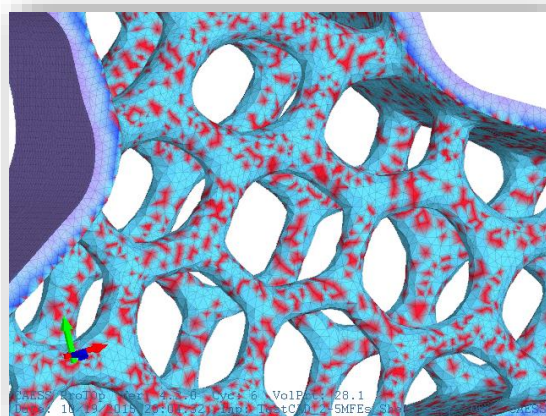

Errors free and smoothed surface

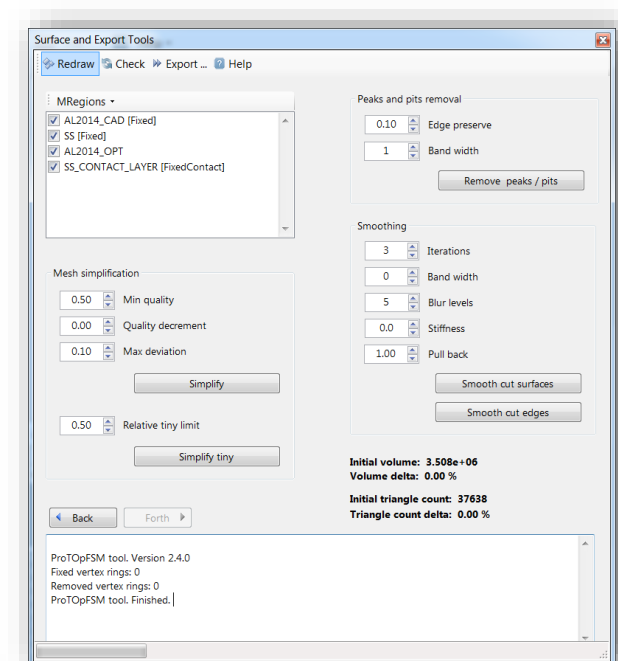
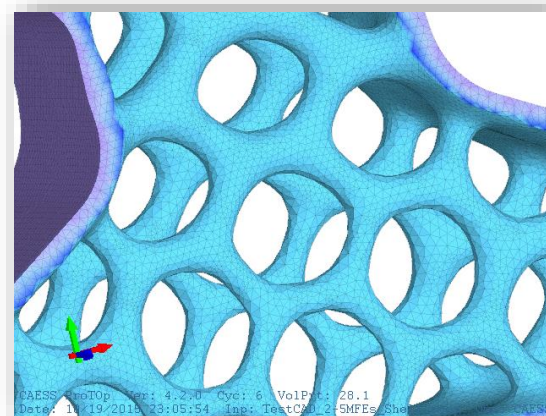

Export to STL, AMF or STEP formats

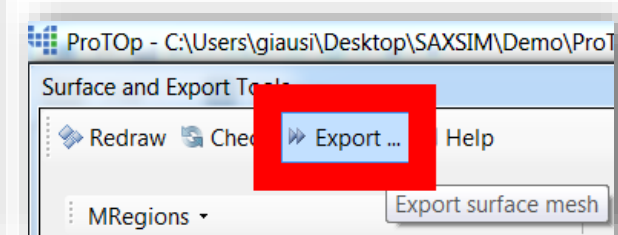

- Export to Additive Manufacturing
- ProTop® solution perfectly suited for new Additive Manufacturing technologies
 - Freedom of design
 - Complex geometry
 - Lattice structure

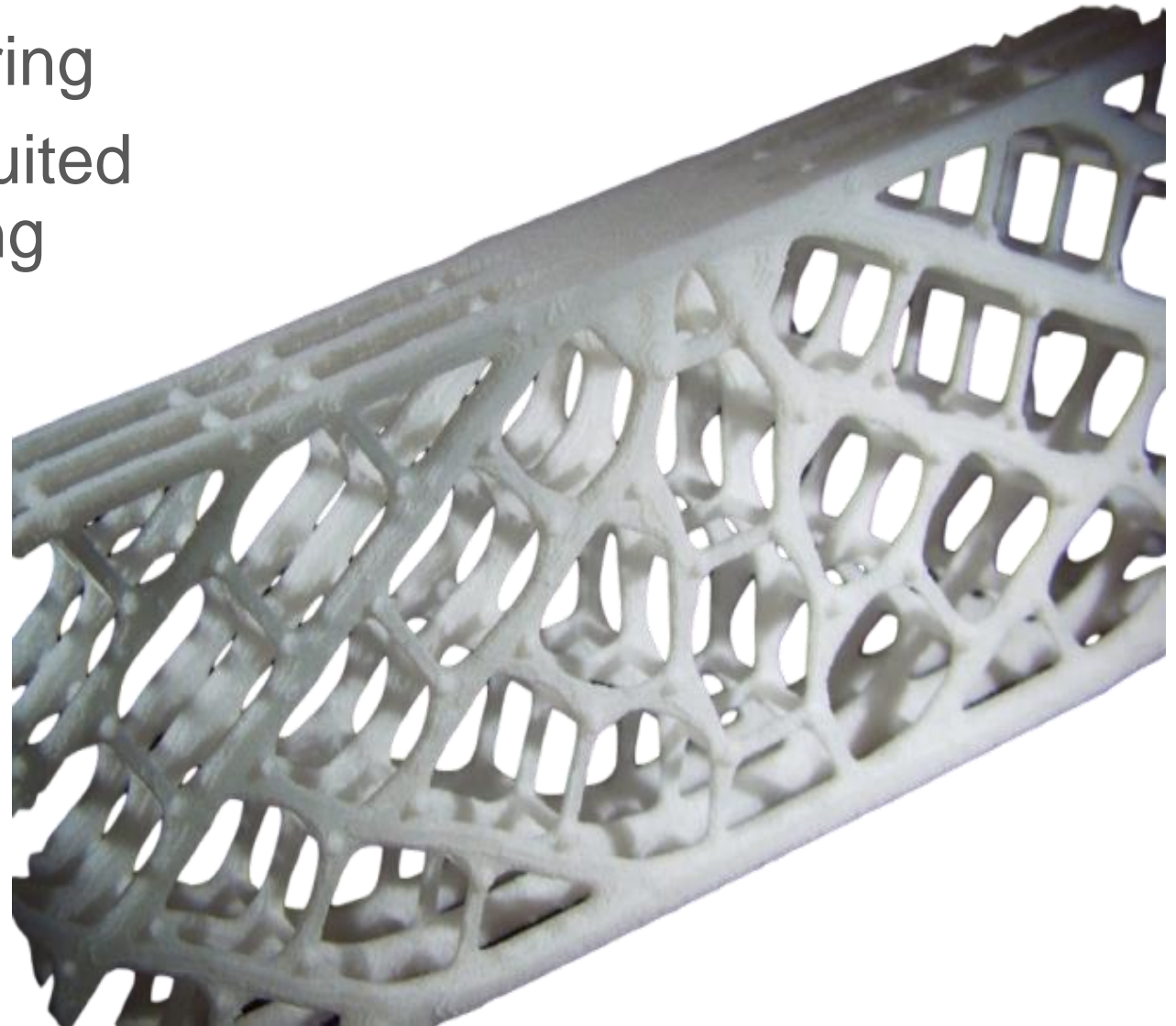

- Export / Reconstruction in Creo Parametric
- Validation FEAs (Creo Simulate)

**STL from
ProTopCI®**

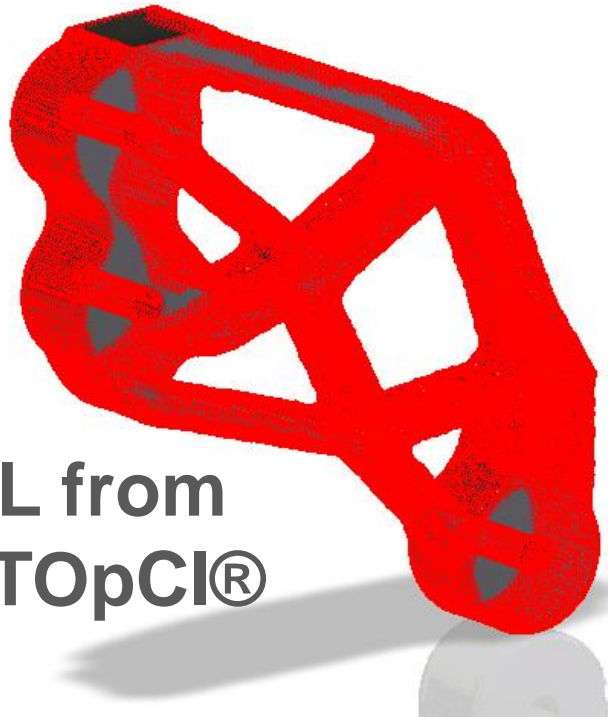

**Creo
Parametric**

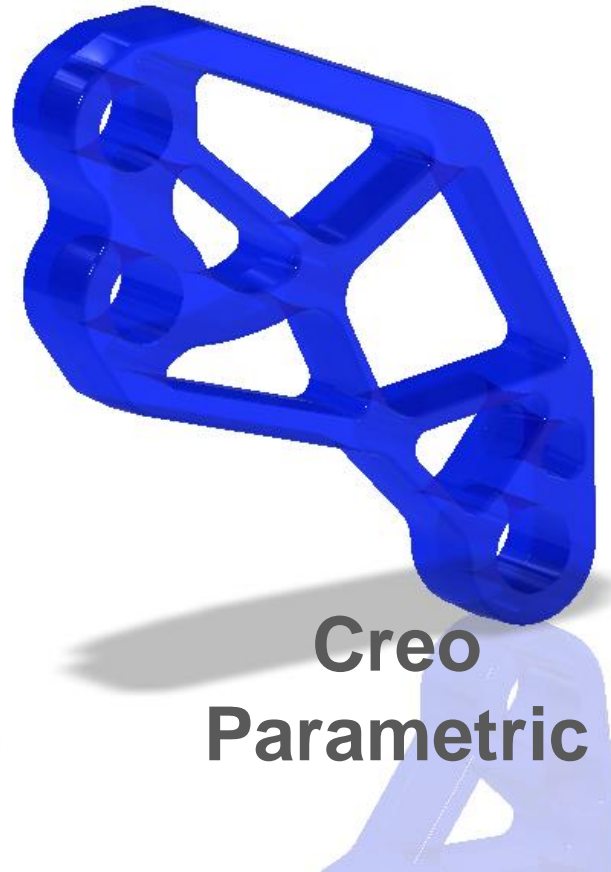

**Creo
Simulate**

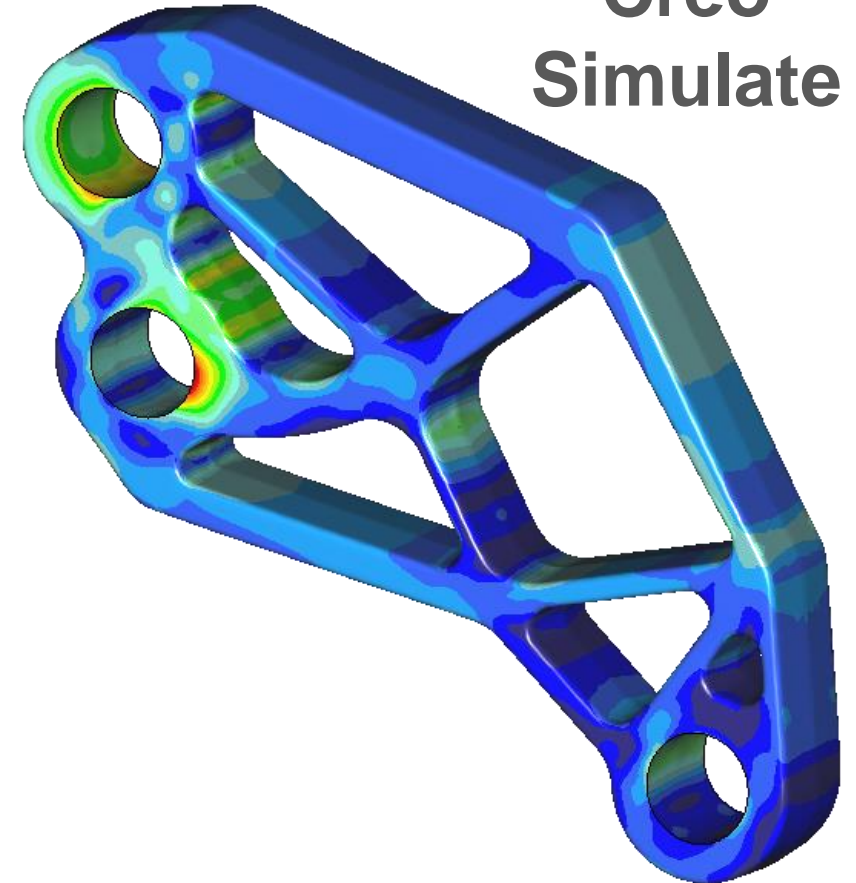

A photograph of a sharp, rocky mountain peak, likely a granite spire, against a clear blue sky. The rock is illuminated from the side, showing its texture and some snow patches at the base. The bottom portion of the image is overlaid with a dark blue gradient.

ProTopCI: Live Demo

ProTopCI: Live Demo

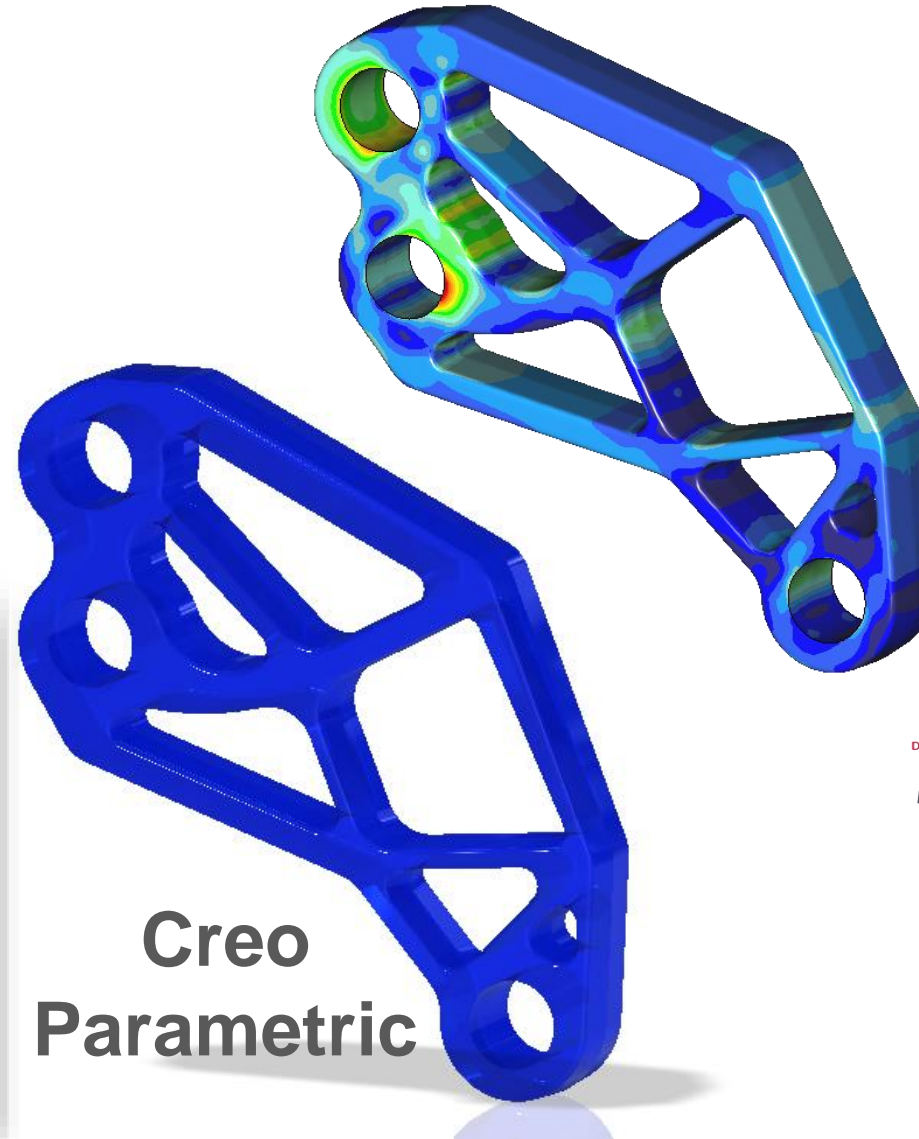
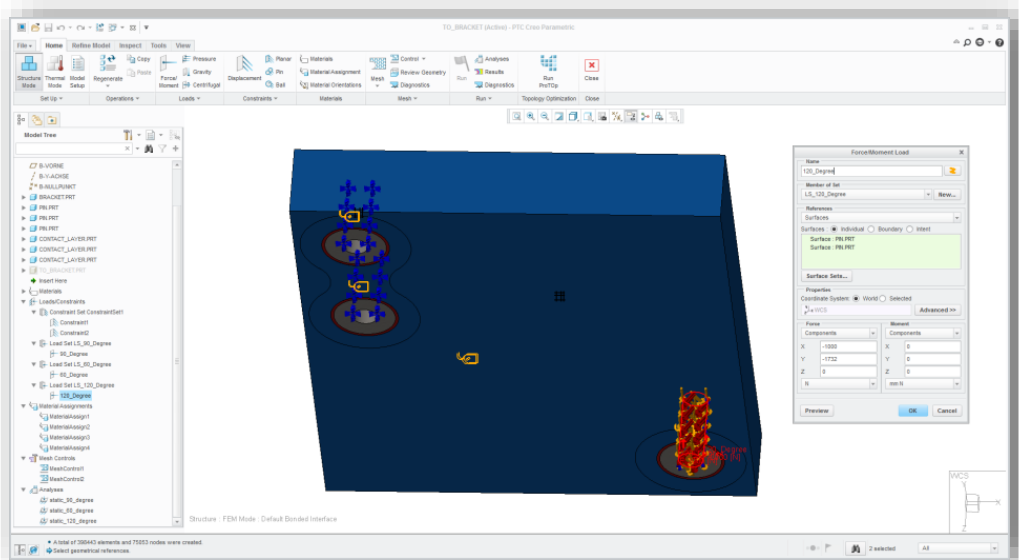

**Creo
Simulate**

**Creo
Parametric**

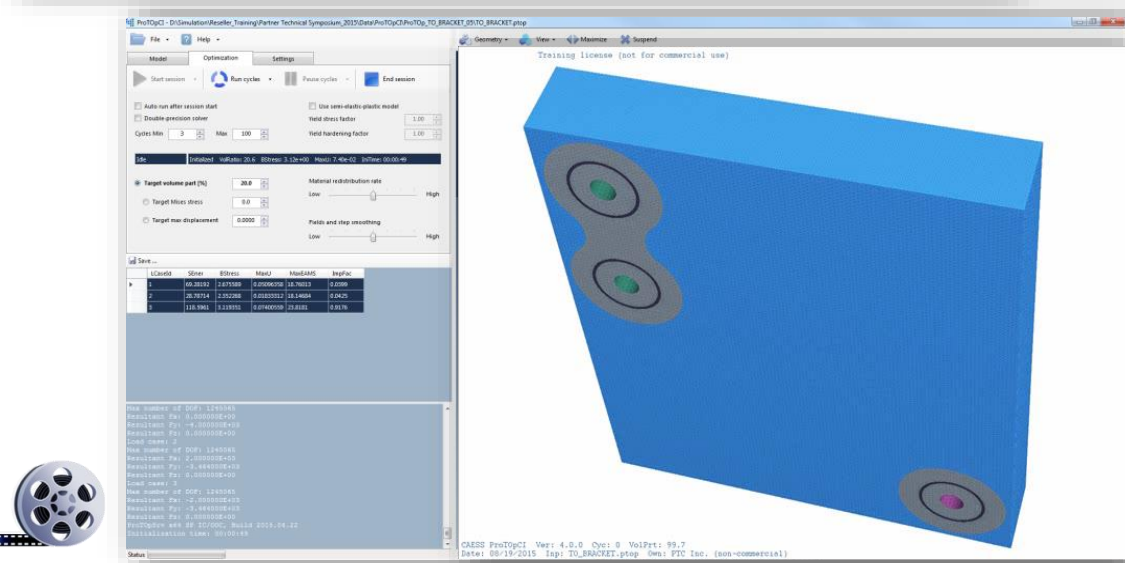
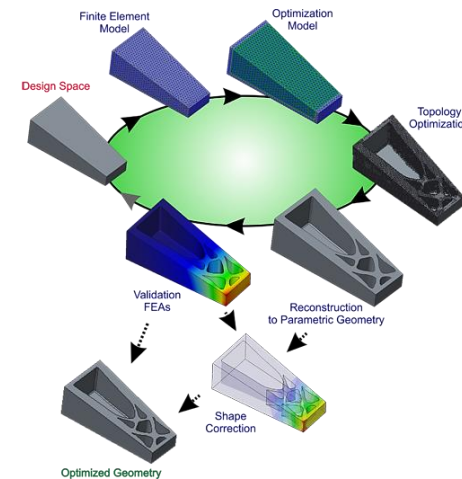

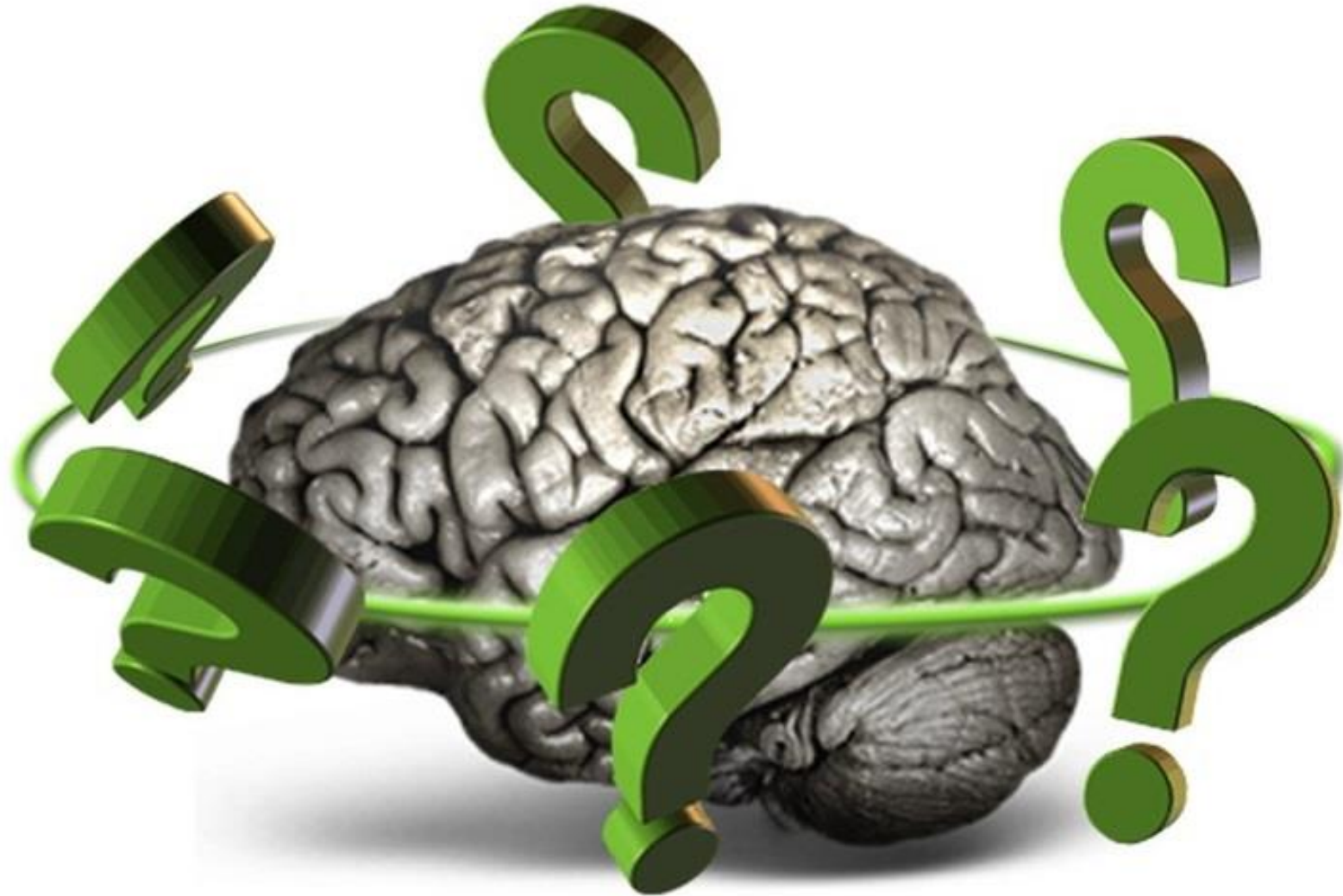

A large, high-resolution photograph of a jagged mountain peak, likely a snow-capped summit, set against a clear blue sky. The peak is illuminated from the side, highlighting its rocky texture and sharp edges. The bottom portion of the image is overlaid with a semi-transparent dark blue gradient.

VIELEN DANK !!!